

Ø eixo mm pol	Caixa	Dimensão nominal (mm)													Paraf.
		a	p	e	i	s	j	k	g	f	F(min.)	t	Zs	Zc	
12 1/2	FC 204	100	78,0	55,1	10,0	12,0	5,0	7	20	62,0	-	2	35	41	M10 3/8
15 5/8															
17 3/4	FC 205	115	90,0	63,6	10,0	12,0	6,0	7	21	70,0	30,0	2	38	45	M10 3/8
20															
7/8 15/16	FC 206	125	100,0	70,7	10,0	12,0	8,0	8	23	80,0	36,0	2	41	48	M10 3/8
25															
1 1-1/16	FC 207	135	110,0	77,8	11,0	14,0	8,0	9	26	90,0	40,0	3	47	51	M12 1/2
1-1/8															
30 1-3/16	FC 208	145	120,0	84,8	11,0	14,0	10,0	9	26	100,0	46,0	3	52	56	M12 1/2
1-1/4															
1-1/4 1-5/16	FC 209	160	132,0	93,3	10,0	16,0	12,0	14	26	105,0	52,0	3	51	58	M14 1/2
1-3/8															
35 1-7/16	FC 210	165	138,0	97,6	10,0	16,0	12,0	14	28	110,0	57,0	3	53	60	M14 1/2
2															
2 2-1/8	FC 211	185	150,0	106,1	13,0	19,0	12,0	15	31	125,0	64,0	4	59	63	M16 5/8
55 2-3/16															

UCFC2 YFC2	CUCFC2 CYFC2	C(E) C(E)	UGFC2 GFC2	UKFC2	D	Rolamentos				UK 200		
						UC 200 / Y 200 z1	UG 200 / G 200 z2	Bi1	Bi2	Ø Eixo	Bucha	z3
0,70	0,90	0,70	-	47,0	28	31,0	36	43,5	-	-	-	-
1,00	1,10	1,10	1,00	52,0	30	34,0	37	44,3	3/4 20	HE2305 H2305	29	35,0
1,30	1,60	1,40	1,40	62,0	32	38,1	40	48,3	7/8 15/16 25 1	HS2306 HA2306 H2306 HE2306	30	38,0
1,60	2,00	1,70	1,70	72,0	36	42,9	43	51,1	1-1/8 30 1-3/16	HS2307 H2307 HA2307	33	43,0
2,00	2,50	2,20	2,10	80,0	41	49,2	46	56,3	1-1/4 1-5/16 1-3/8 35	HE2308 HA2308 HS2308 H2308	35	46,0
2,70	3,30	2,90	2,80	85,0	40	49,2	45	56,3	1-7/16 1-1/2 40 1-5/8	HA2309 HE2309 H2309 HS2309	36	50,0
2,90	3,60	3,20	3,00	90,0	43	51,6	48	62,7	1-11/16 1-3/4 45	HA2310 HE2310 H2310	37	55,0
4,20	5,00	4,50	4,20	100,0	46	55,6	57	71,3	1-7/8 1-15/16 50 2	HS2311 HA2311 H2311 HE2311	41	59,0

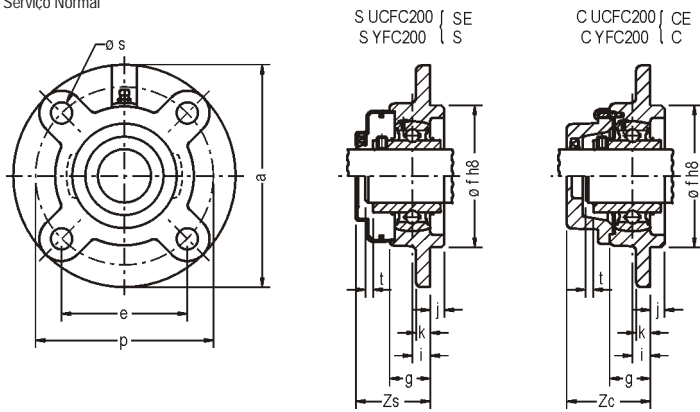

Ø eixo mm pol	Caixa	Dimensão nominal (mm)													Paraf.
		a	p	e	i	s	j	k	g	f	F(min.)	t	Zs	Zc	
2-1/4 60 2-3/8 2-7/16	FC 212	195	160,0	113,1	17,0	19,0	12,0	15	36	135,0	69,0	4	68	74	M16 5/8
2-1/2 65	FC 213	205	170,0	120,2	16,0	19,0	14,0	15	36	145,0	74,0	4	-	76	M16 5/8
65 2-11/16 2-3/4 70	FC 214	215	177,0	125,1	17,0	19,0	14,0	18	40	150,0	-	4	-	84	M16 5/8
2-15/16 75 3	FC 215	220	184,0	130,1	18,0	19,0	16,0	18	40	160,0	84,0	4	-	86	M16 5/8
80 3-3/16	FC 216	240	200,0	141,4	18,0	23,0	16,0	18	42	170,0	90,0	4	-	90	M20 3/4
3-1/4 85	FC 217	250	208,0	147,1	18,0	23,0	18,0	20	45	180,0	95,0	5	-	96	M20 3/4
3-1/2 90	FC 218	265	220,0	155,5	22,0	23,0	18,0	20	50	190,0	102,0	5	-	104	M20 3/4

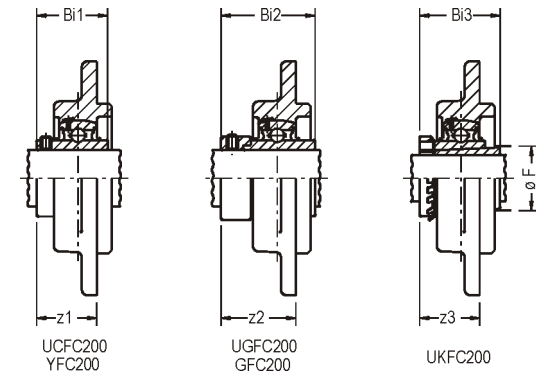

Peso (Kg)				D	Rolamentos							
UCFC2 YFC2	CUCFC2(E) CYFC2(E)	UGFC2 GFC2	UKFC2		UC 200 / Y 200 z1 Bi1		UG 200 / G 200 z2 Bi2		UK 200 Ø Eixo Bucha z3 Bi3			
4,90	6,30	5,20	4,80	110,0	57	65,1	64	77,7	2-1/8 55	HS2312 H2312	48	62,0
5,40	7,20	6,00	5,40	120,0	56	65,1	68	85,7	2-3/16 2-1/4 60 2-3/8	HA2313 HE2313 H2313 HS2313	48	65,0
6,60	8,00	7,30	-	125,0	61	74,6	69	85,7	-	-	-	-
6,90	9,00	7,50	7,30	130,0	62	77,8	73	92,1	2-1/2 65	HE2315 H2315	53	73,0
8,60	11,10	8,90	9,10	140,0	67	82,6	76	95,2	2-3/4 70	HE2316 H2316	57	78,0
10,00	12,90	-	10,40	150,0	70	85,7	-	-	75 3	H2317 HE2317	58	82,0
12,30	16,00	11,50	12,50	160,0	78	96,0	68	69,5	80	H2318	64	86,0