

Ø eixo mm pol	Caixa	Dimensão nominal (mm)							Paraf.
		a	e	i	g	l	s	b	
12 1/2	FT 203 ⁽¹⁾	112	76,2	17,1	11	25	10,5	60	M8 5/16
15 5/8									
17 3/4	FT 204	112	89,7	14,3	11	25	10,5	60	M8 5/16
20									
7/8 25 1	FT 205	124	98,8	15,9	13	27	12,5	70	M10 3/8
1-1/16									
1-1/8 30	FT 206	141	116,7	17,9	13	30	12,5	83	M10 3/8
1-3/16									
1-1/4 1-1/4	FT 207	156	130,2	19,1	14	34	14,0	95	M12 1/2
1-5/16									
1-3/8 35	FT 208	171	143,7	21,0	14	38	14,0	105	M12 1/2
1-7/16									
1-1/2 40	FT 209	179	148,4	21,8	14	40	16,0	111	M14 1/2
1-5/8									
1-11/16 1-3/4	FT 210	189	157,2	22,2	14	40	16,0	116	M14 1/2
45									
1-13/16 1-7/8	FT 211	224	184,2	25,4	21	44	18,0	128	M16 5/8
1-15/16									
50 2	FT 213	260	212,5	29,5	21	50	27,0	156	M20 3/4
2									
2-1/8 55									
2-3/16 2-1/2 65									

⁽¹⁾ - montado com rolamento B203 V22 FRM em lugar de UC 200.

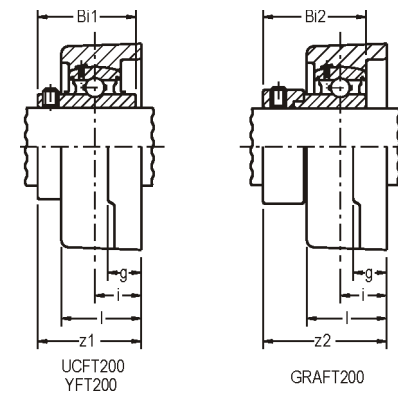

Peso (Kg)		D	Rolamentos			
UCFT2 YFT2	GRAFT2		UC 200 / Y 200		GRA 200	
			z1	Bi1	z2	Bi2
0,40	0,50	40,0	33	22,0	39	28,6
0,50	0,40	47,0	32	31,0	38	31,0
0,60	0,60	52,0	35	34,0	39	31,0
0,90	0,90	62,0	40	38,1	45	35,7
1,30	1,40	72,0	44	42,9	48	38,9
1,70	1,70	80,0	51	49,2	54	43,7
1,90	1,80	85,0	52	49,2	54	43,7
2,10	1,90	90,0	55	51,6	55	43,7
3,20	2,70	100,0	59	55,6	62	48,3
4,80	-	120,0	69	65,1	-	-